

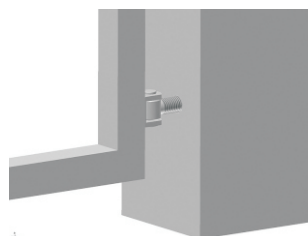

ISO 9001

Art. HL 20 G HL 24 G

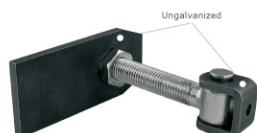

- ⒼⒷ) ADJUSTABLE HINGE WITH PLATE, FIXED
- Ⓓ) TORBAND REGULIERBAR MIT PLATTE FÜR BETONSTEHER
- Ⓕ) GOND RÉGLABLE AVEC PLATINE, FIXÉ
- Ⓔ) BISAGRA AJUSTABLE CON PLATO, FIJA
- Ⓟ) DOBRADIČA AJUSTÁVEL COM PLACA, FIXA
- Ⓘ) CERNIERA REGOLABILE CON PIASTRA, FISSA
- ⒸⓏ) PANT REGULOVATELNÝ S PLOTNOU PRO ZDĚNÉ A KOVOVÉ SLOUPY
- ⓃⓁ) VERSTELBARE SCHARNIER MET PLAAT, VASTGESCHROEFD
- ⒹⓀ) INDSTILLELIGT HÆNGSEL MED PLADE, FAST
- Ⓝ) JUSTERBART HENGSEL MED PLATE, FAST
- Ⓢ) JUSTERBART GÅNGJÄRN MED PLATTA, FAST
- ⒻⒿ) SÄÄDETTÄVÄ SARANA LEVYLLÄ, PYSYVÄ

- ⒼⓊⓈ) РЕГУЛИРУЮЩАЯСЯ ПЕТЛЯ С ПЛАСТИНОЙ ДЛЯ БЕТОННЫХ И МЕТАЛЛИЧЕСКИХ СТОЛБОВ
- ⒹⓇ) PLAKALI AYARLANAB İLİR MENTEŞE, SABİT
- ⒶⓇ) 鐵板固定式可調較鏈
- ⒸⓗⓃ) 帶鉸鏈板的固定式可調較鏈
- ⓂⒶⓁ) ENGSEL BOLEH LARAS DENGAN PLAT, TETAP
- Ⓕ) ÁLLÍTHATÓ ZSANÉR LEMEZSEL, RÖGZÍTETT
- ⓅⓁ) ZAWIAS REGULOWANY Z PŁYTKĄ, PRZYKRĘCANY
- ⓈⓀ) PÁNT REGULOVATEĽNÝ S PLATŇOU PRE MUROVANÉ A KOVOVÉ STĽPY
- Ⓡⓞ) BALAMA REGLABILĂ CU PLACĂ, FIXĂ
- ⒻⓇ) PRILAGODLJIVI ZGLOB S PLOČOM, UGRADNJA ZAVRTNJIMA
- ⓈⓁⓐ) NASTAVLJIVI TE ČAJ S PLOŠČO, FIKSNI

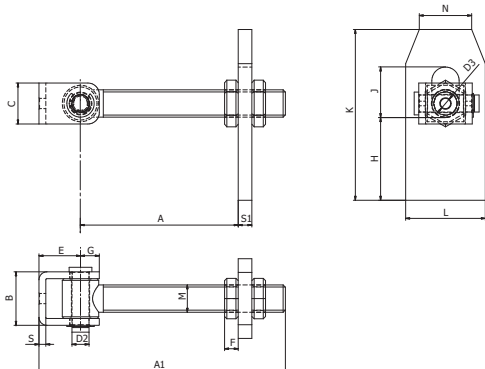

Art.	M	A	A1	B	C	D2	D3	E	F	G	S	S1	K	L	H	J	N	1 pc				
		mm						O		mm						kg	pcs	kg				
HL 20 G	M20	178	35-140	39	30	14	9	23	9	18	6	8	135	60	80	40x20	40	1,04	10	10,4		
HL 24 G	M24	208	45-150	48	36	16	9	30	12	20	6	12	150	70	73	43x24	45	1,87	4	7,48		